



VAPOTHERM®



Precision Flow® Heliox

Instructions For Use

Table of Contents

Page

	Symbols	3
Section 1	Indications, Warnings and Cautions	4
Section 2	Overview	7
Section 3	Principles of operation	8
Section 4	Controls, displays & connections	10
Section 5	Modes of operation	13
Section 6	Initial assembly	14
Section 7	Setting up	15
Section 8	Adjustments	19
Section 9	Connecting to patient	20
Section 10	Operating guidelines	21
Section 11	Changing the disposable patient circuit	22
Section 12	Alarms	23
Section 13	Shut down	27
Section 14	Routine maintenance	27
Section 15	Cleaning and disinfection	28
Section 16	Specifications	29
	Appendix:	
	Audio Tone Characteristics	32
	Software modes	33
	EMC Guidance	34

Precision Flow® Heliox Packaging contains:

- Precision Flow® Heliox Unit
- Instructions for Use (USB)
- Quick Reference Guide
- Power Cord
- O₂ Sensor Cell
- US ONLY- Heliox and Oxygen Hoses
- Delivery Tube clip



Attention:
consult
manual



Alternating
current



Mute
alarms



Run/stop



MR Unsafe



Single patient
use



Protective
earth



Do not
cover



Type BF
Class 1



IPX1
Drip-proof



Vapotherm Inc. has declared that this product conforms with the European Council Directive 93/42/EEC Medical Device Directive when it is used in accordance with the instructions provided in the Instructions For Use.



This symbol indicates that the waste of electrical and electronic equipment must not be disposed as an unsorted municipal waste and must be collected separately. Please contact an authorized representative of the manufacturer for information concerning the decommissioning of your equipment.

Section 1 Indications, Warnings and Cautions

General Indications & Contraindications.

Primary Indications:

The Precision Flow® Heliox is intended to add warm moisture to breathing gases from an external source for administration to a neonate/infant, pediatric and adult patients in the hospital, subacute institutions, and home settings. It adds heat and moisture to a blended medical heliox (79% helium, 21% oxygen)/ oxygen mixture and assures the integrity of the precise heliox/oxygen mixture via an integral oxygen analyzer. The flow rates may be from 1 to 40 liters per minute via nasal cannula.

Contraindications:

General:

- Not appropriate for patients who are not spontaneously breathing, are unable to protect their airway or have anatomic or injury induced blockage of the nasal pathway to the nasopharyngeal space
- Not for treating OSA and snoring
- The Precision Flow® Heliox is not for field transport
- The Precision Flow® Heliox is MRI unsafe. Do not use it in an MR environment.

Warnings and Cautions

A **Warning** indicates that a situation may occur which is potentially harmful to the patient or user. A **Caution** indicates a condition that may lead to equipment damage, malfunction, or inaccurate operation. A **Note** indicates a point of emphasis to make operation more efficient or convenient.

Please take the time to familiarize yourself with the warnings, cautions, and notes listed in these instructions. They cover safety considerations, special requirements, and regulations.

The user of this product shall have sole responsibility for any malfunction due to operation or maintenance performed by anyone not trained by VapoTherm staff or official training documentation.

When handling any part of the Precision Flow® Heliox, always follow hospital infection control guidelines and Standard Precautions. VapoTherm also recommends that users follow the Centers for Disease Control (CDC) publications: Guidelines for Maintenance of In-Use Respiratory Therapy Equipment and Guidelines for Prevention of Nosocomial Pneumonia.

General Warnings

Federal Law (U.S.) restricts the sale of this device to, or by the order of any physician. This device should be used **ONLY** by a trained respiratory therapist or certified operator. Training is to be provided and shall be conducted by authorized VapoTherm personnel only.

This is a humidification device generally used for providing continuous flows of breathing gas.

The Precision Flow® Heliox is not a ventilator and should not be used as life support.

Oxygen supports combustion; this device should not be used near or around open flames, oil, or grease, or flammables.

Service on the device should only be performed by qualified, certified service technicians.

To prevent injury, do not attempt to do any service to the Precision Flow® Heliox while a patient is connected to the device.

Section 1 Indications, Warnings and Cautions

The Precision Flow® Heliox is designed only for use with a 79% Helium/21% Oxygen Heliox mixture (80:20). Other Helium Oxygen mixtures must not be used.

If the device is damaged or not working properly, do not use. Contact Vapotherm or your authorized Vapotherm representative.

Do not operate if power cord is damaged.

No modification of the equipment is allowed. Do not modify this equipment without authorization of Vapotherm. If this equipment is modified, appropriate inspection and testing must be conducted to ensure continued safe use of the equipment.

The device should not be placed in run mode and left unattended in a non-care environment. When utilized in a care environment, operator shall remain close enough to hear the alarms.

Do not use the Precision Flow® Heliox at an altitude above 6,392 feet or outside a temperature of 18-30°C. Using the Precision Flow® Heliox outside of this temperature range or above this altitude can affect the quality of the therapy or injure the patient.

Do not use the Precision Flow® Heliox in or around water, other than the sterile water supply that feeds the system.

Do not use the Precision Flow® Heliox system in combination with any other system intended for humidification of respiratory gases (e.g. heat and moisture exchangers (HMES)).

Do not add any attachments or accessories to the Precision Flow® Heliox that are not approved by Vapotherm. Unauthorized attachments or accessories may affect the quality of the therapy.

Prior to use, the Precision Flow® Heliox should be positioned and secured to a Vapotherm approved roll stand with the base of the unit no more than 40" (102cm) above the floor to reduce risk of tipping.

Make sure all Disposable Patient Circuit connections have been properly secured.

The vapor transfer cartridge, disposable water path and delivery tube are labeled as **single patient use** only and must be replaced after 30 days use on a single patient (nasal cannula replaced as required); do not attempt to sterilize or reuse and follow all local and federal regulations for disposal. Outside the USA follow national or international regulations. Reuse of any of these components may result in mechanical failure and/or increased risk of bacterial contamination.

Failure to utilize sterile water supply or clean gas supply may increase risk of bacterial contamination.

- Use aseptic technique.
- Gas supply must be clean dry medical grade gas to prevent harm to the patient and prevent damage to the Precision Flow® Heliox

Precision Flow® Heliox **is not a Continuous Positive Airway Pressure (CPAP) device.**

There are no controls to deliver or monitor airway pressure. Precision Flow® Heliox should not be used to deliver pressure in a closed system.

Never connect the unit to a patient until it reaches at least 33°C. Allow the unit to warm-up to purge condensate and prevent patient discomfort due to cold or partly humidified gas.

Patients receiving supplemental oxygen are acute and appropriate clinical vigilance should be observed by the care team. Additional patient monitoring including pulse oximetry is necessary if the Precision Flow® Heliox is used to give supplementary oxygen.

The Precision Flow® Heliox **is MRI unsafe.** Do not use it in an MR environment.

Section 1 Indications, Warnings and Cautions

The unit is provided with a Hospital Grade power cord. Do not use any other cord. **Do not use extension cords.** For grounding reliability, the cord must be connected to an equivalent receptacle marked "Hospital Grade" or "Hospital Only." If any doubt exists as to the grounding connection, **do not** operate the device.

Medical electrical equipment needs special precautions regarding electromagnetic radiation. Portable and mobile RF communications equipment can affect medical equipment and should not be used near the Precision Flow® Heliox.

The back-up battery is designed for temporary use only, when AC power to the unit has been interrupted. The internal battery backup maintains flow and oxygen percentage for at least 15 minutes if AC power is cut off. When the Precision Flow® Heliox is running on battery, there is no heat or humidity provided with the set flow and FiO₂ and humidity level may drop below safe limits. After the battery is fully discharged the device will not operate and patient gas flow will cease. There are no alarms or display indicators after the battery has discharged. The battery is not intended for patient transport.

To reduce the risk that the patient may aspirate condensed water from the breathing circuit, regularly observe the patient and output of the patient interface for excess water, and if detected, remove patient interface from the patient. Water in the center lumen can result from condensation or due to a leak from the outer lumens that surround the breathing circuit.

General Cautions

Read and understand these instructions prior to operating the system.

Clamp sterile water supply when not in use, including Standby mode, to prevent damage by water ingress.

Aseptic techniques (including hand washing and avoiding touching connection points) and Standard Precautions should always be followed when handling medical equipment. Standard Precautions should always be followed when coming into contact with patients.

Do not cover the unit; blocking the vent may damage the unit.

Do not:

- Immerse the Precision Flow® Heliox in water.
- Steam or gas sterilize the Precision Flow® Heliox.
- Wipe with chlorine bleach solution greater than 2% strength.

Flexible sterile water bags are recommended. If rigid or semi-rigid bottles are used, a VapoTherm approved adapter must be used.

NOTE: Interdependence of FiO₂ and Flow are directly related to input supply pressure. The Precision Flow® Heliox may be operated with limited performance at gas inlet pressures as low as 4 psi (28 kPa); however, for the full specified range of gas flows and oxygen percentages, both gas inlet pressures must be 40 psi (276 kPa) or above. When both or either of the supply pressures are less than 40 psi, the Precision Flow® Heliox calculates the maximum achievable flow and/or titration and limits the user adjustable parameters on the user interface.

The maximum limited pressure and maximum operating pressure of the Precision Flow® Heliox is 20 psi (138 kPa).

Precision Flow® Heliox is not for field transport. When used with approved ancillary equipment, the Precision Flow® Heliox may be used for transferring patients within the hospital.

Section 2 Overview

The Precision Flow® Heliox is a system for high flow humidified respiratory therapy by a Vapotherm approved interface. It incorporates the Vapotherm core humidification technology with an electronic blender and flow controller. The water and gas pathways are both incorporated into a removable, disposable patient circuit.

Features

- The patient circuit is detachable and disposable: no disinfection necessary
- Minimal downtime between patients: less than five minutes to change disposables
- Built-in oxygen/heliox blender
- Built-in electronic flowmeters and controllers
- Self-testing and self-calibrating
- Internal battery backup maintains flow and oxygen percentage for at least 15 minutes if AC power is cut off. Battery recharges in 2 hrs.
- All internal sensors are self-calibrating and self-monitoring
- Single button starts and stops the device
- Temperature, flow and oxygen percentage are adjusted via a single setting control knob on the front panel
- All values and alarms displayed in a single large color-coded panel
- Flow range 1-40 L/min
- Oxygen percentage is fully adjustable from 21 to 100% when two 40 psi (276 kPa) gas sources are used
- Inlet gas pressure range is 4-85 psi (28-586 kPa)
- Single gas operation the Precision Flow® Heliox detects inlet gas pressure and blends flow based on demand required and available supply. Supply pressure determines FI_{O_2} and delivered flow; if demand exceeds supply an alarm sounds
- At low gas inlet pressures, maximum flow rate and oxygen percentage settings are automatically reduced to match the inlet pressure
- Automatically senses cartridge type: maximum flow setting is automatically reduced if low-flow cartridge is installed
- Warm-up time less than five minutes
- Sterile water supply is connected to the disposable water path using a standard spike
- Universal power requirements allow use anywhere with only a change of power cord
- Scheduled maintenance: oxygen sensor replaced annually, battery replaced every two years



Precision Flow® Heliox

Section 3 Principles of operation

The Precision Flow[®] Heliox warms and humidifies breathing gas for delivery by a Vapotherm approved interface at flows from 1 to 40 L/min. The unit incorporates an electronic blender and flow sensors that allow the oxygen percentage and total gas flow to be set independently.

The Precision Flow[®] Heliox consists of two parts:

Main unit

- The **capital unit** which contains all the electrical and electronic components including the electronic blender and flow controllers, and remote sensors to monitor the disposable water path. The main unit has no water pathways and the gas pathway contains only dry gas at room temperature, and consequently does not need internal cleaning or disinfection.
- The flow of oxygen and air are measured by **mass flow sensors**. The operating software calculates the required flow of each needed to reach the target flow and oxygen percentage set by the operator. The system controls gas flows accordingly by adjusting proportional **solenoid valves** on the gas lines. An **oxygen sensor** monitors the gas mixture and signals any discrepancy between target and measured percentage. The oxygen sensor is automatically calibrated with oxygen at power-up and every 24 hours.
- **Firmware** running in the main unit uses sensors to monitor gas pressure, water temperature, and to detect air leaks into the disposable patient circuit (bubble detector). Alarms are displayed if any parameters are outside the normal range. Other indicators show low charge in the backup battery, and the type of cartridge installed. See Appendix for a description of the firmware states and transitions.
- After a two hour charging period, an internal **battery** backup will maintain the set flow and oxygen blend for at least 15 minutes without AC power.

WARNING: The back-up battery is designed for temporary use only, when AC power to the unit has been interrupted. When the Precision Flow[®] Heliox is running on battery, there is no heat or humidity provided with the set flow and FiO_2 and humidity level may drop below safe limits. After the battery is fully discharged the device will not operate and patient gas flow will cease. When fully charged, the battery provides 15 minutes of power. The battery is not intended for patient transport.

Disposable patient circuit

- The **disposable patient circuit (DPC)** is comprised of the disposable water path (DWP), vapor transfer cartridge (VTC) and delivery tube. Conditions in the circulating water and gas streams are sensed remotely via the interface between the main unit and the disposable water path.
- **Vapor transfer cartridge.** In the cartridge, blended gas passes through the lumens of hundreds of parallel hollow fibers made of a specially developed polymer. Warm water circulates around the fibers and diffuses as vapor through the fiber material into the gas stream flowing through each fiber. Unlike most humidifiers, there is no direct contact between the water and gas streams. The gas stream leaves the cartridge saturated with vapor at the set temperature.



Note: Use **only** approved cartridges from Vapotherm Inc.

Section 3 Principles of operation

- Patient delivery tube.** The warmed humidified gas passes through the center of a triple-lumen heated delivery tube. The center lumen is surrounded by two outer lumens circulating warmed water to maintain the temperature of the inner lumen and to minimize rain-out. A proprietary short nasal cannula is connected to the end of the delivery tube and passes the humidified breathing gas to the patient's nares. It is normal for non-DEHP PVC tubing to appear slightly cloudy, or yellow, especially during longer use or when operated at higher temperatures.
- Disposable water path.** The disposable water path houses a water reservoir, pump, connections for the vapor transfer cartridge and delivery tube, and sensor interfaces to the main unit. Water is pumped past a heater plate through the outer lumens of the delivery tube. Returning water passes through the outer jacket of the specially designed vapor transfer cartridge where some water is lost as vapor to the gas stream. There is no direct contact between water and gas flows. The water then returns to the pump reservoir. Heater power automatically maintains the set temperature. Water flows into the circuit from the sterile water supply to replace evaporative losses in the vapor transfer cartridge. Air is purged to atmosphere from the circulation via a hydrophobic filter membrane.

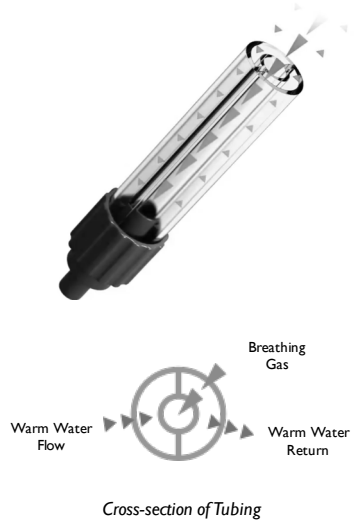

See Section 5 for a description of the modes of operation.

Section 4 Controls, displays & connections



- | | |
|---|-------------------------|
| 1. Battery low or charging | 9. Alarm mute button |
| 2. Disposable water path faulty or absent | 10. Alarm muted LED |
| 3. Vapor transfer cartridge type | 11. General fault |
| 4. Vapor transfer cartridge fault | 12. Water out |
| 5. Gas supply fault | 13. Blocked tube |
| 6. Run/Stop Status LED | 14. Temperature Display |
| 7. Run/Standby button (see note) | 15. Flow Display |
| 8. Setting control knob | 16. Oxygen % Display |

Note: The Precision Flow® Heliox has no ON/OFF switch. Plug the unit into a wall outlet to keep the battery fully charged.

Section 4 Controls, displays, & connections



Front view

1. Folding carrying handle
2. Multi-function display:
 - Shows set values for oxygen %, flow and temperature
 - Icons indicate alarm conditions and device status
3. Alarm mute:
 - Press to silence alarms for up to 2 minutes
 - LED indicates one or more alarms are muted
4. Setting control knob:
 - Press to select which variable to adjust
 - Rotate to adjust to parameter value
 - Press again to set value

5. Hinged door:
 - Opens to install or remove disposable water path
6. Status light:
 - Amber flashing in Sleep mode
 - Amber solid in Standby mode
 - Flashing green in Run mode when output does not match settings (e.g. during warmup)
 - Steady green in Run mode when unit is operating normally
7. Run/standby button:
 - Press to start unit after water, DPC, and gas are connected



Section 4 Controls, displays, & connections

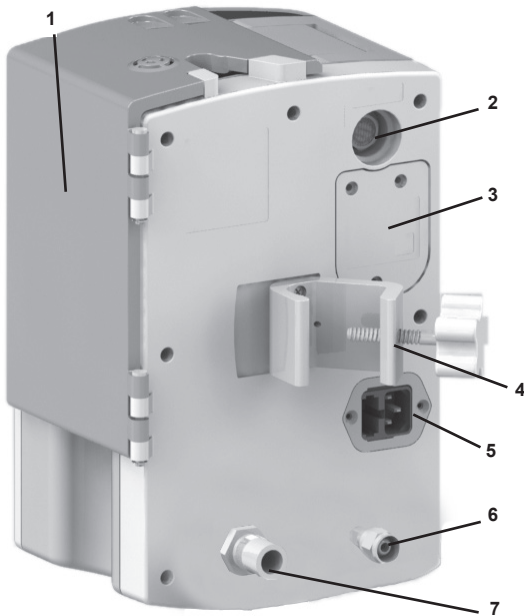

Rear view

1. Hinged door
 - Open to install or remove disposable water path
2. Vent
3. Access panel for O₂ sensor (see note)
4. Pole clamp
5. Power cord connection and fuse holder
6. DISS or NIST oxygen connection
7. DISS or NIST heliox connection

Note: Using a permanent marker, write an expiration date on the O₂ sensor cell that is one year from the date it is removed from its packaging.

Section 4 Controls, displays, & connections

Docking station for disposable water path



WARNING:
Heater plate may
be hot!

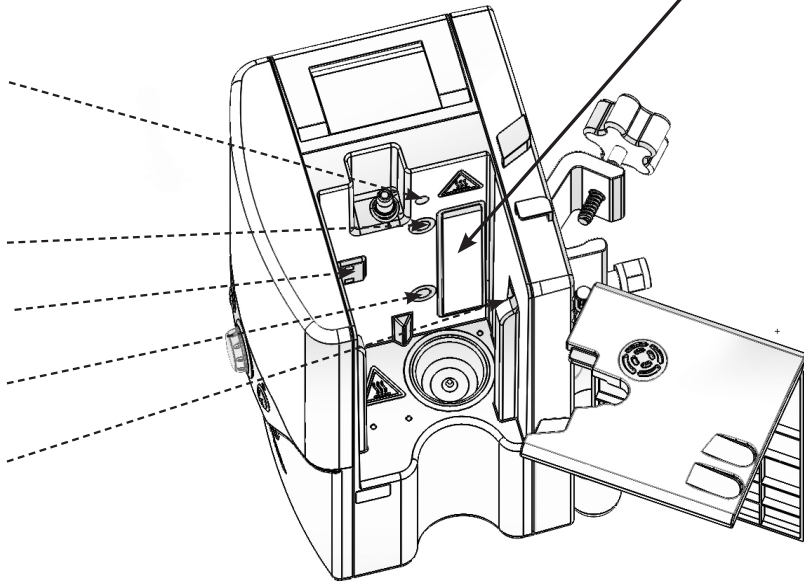

Arrows show locations of optical sensor ports.

Do not scratch or scrub the ports.

Do not apply organic solvents or bleach.

Section 5 Modes of operation

Mode	Action	Indicator light color
Sleep	Display in sleep mode, no gas flow	Amber
Standby	Input parameters can be adjusted, no gas flow	Amber
Run	Warming to set point temperature, gas flow Unit operating at set point, gas flow	Flashing green Solid green

See Appendix for a description of the software operating modes.

Section 6 Initial assembly

Certain accessories must be installed in the Precision Flow® Heliox unit before it can be used. These will normally be supplied in a separate package from the main unit as some are country-specific. The power cord plugs into the IEC60320-compliant receptacle on the rear panel.

WARNING: Do not position the Precision Flow® Heliox so that it is difficult to operate the disconnection of the device.

6a. Oxygen sensor installation

CAUTION: The oxygen sensor is in a sealed package. Un-sealing the package admits oxygen to the sensor, which should be replaced after 1 year. Do not open the package until the unit is to be used. Write the expiration date on the oxygen sensor cell.

1. Loosen three (3) captive screws from the access panel. Pull the panel away from the unit.
2. Insert the threaded end of oxygen sensor into port, and screw into place. Sensor should be hand-tight only. Do not use tools.
3. Plug sensor cable into connector. Replace cover. When replacing cover, be certain not to pinch cables. Do not over-tighten screws.

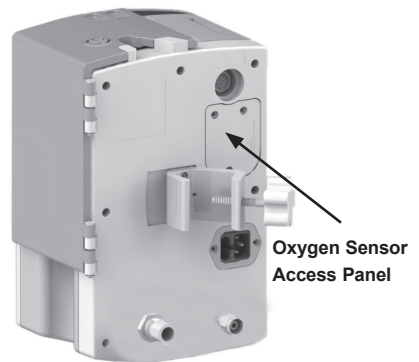

Section 7 Setting up

- 7-1. Hang the sterile water supply from hook on Vapotherm approved roll stand.
- 7-2. Attach the unit to Vapotherm approved roll stand below lowest point of the sterile water supply.

NOTE: The Precision Flow® Heliox oxygen and heliox inlet fittings are gas-specific to ensure correct connection

WARNING: Unit weighs 10.6 lb.(4.81kg) To prevent possible injury or damage from falling, it must be securely fixed to a Vapotherm approved roll stand, with the base of the unit not more than 40" (102cm) above the floor. Fixed rail supports may also be used.

Use with Vapotherm approved roll stands.

- 7-3. Connect oxygen and air supply hoses to correct inlets, then connect them to the wall outlets.
- 7-4. Connect power cord.
- 7-5. Open the bags containing the disposable water path, vapor transfer cartridge, and delivery tube, and assemble them as follows:
 - 7-5-1. Remove the rubber plugs from the vapor transfer cartridge.

Install a high or low-flow vapor transfer cartridge in disposable waterpath as shown. The vapor transfer cartridge may be inserted either way up. Align the vapor transfer cartridge ports with the disposable water path openings and press firmly into place.

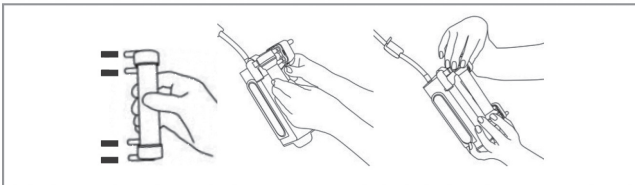

A High Flow Vapor Transfer Cartridge is shown below. It is indicated with a REF: PF-VTC-HIGH and blue caps. High Flow Cartridges are for flow rates of 5-40 L/min.

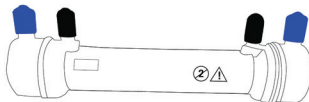

A Low Flow Vapor Transfer Cartridge is shown below. It is indicated with a REF: PF-VTC-LOW, red caps and the addition of two black stripes. Low Flow Cartridges are for flow rates of 1-8 L/min.

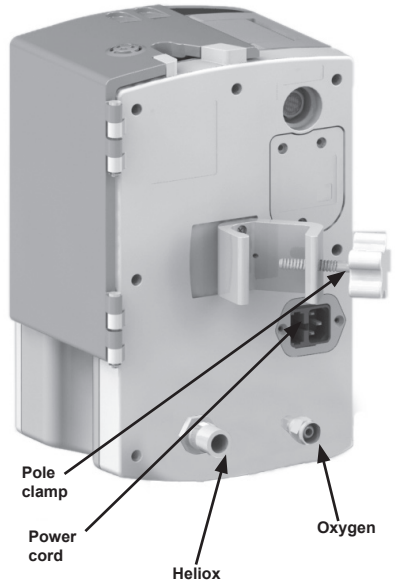

Section 7 Setting up

- 7-5-2. Connect the delivery tube to the disposable water path as shown.
Press firmly into place.

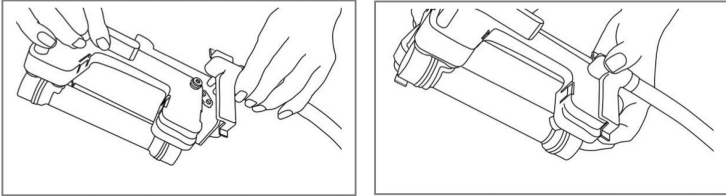

7-6. Inserting disposable patient circuit:

- 7-6-1. Open door to expose the docking station.
7-6-2. Hold disposable patient circuit by its handle, with the delivery tube downward as shown.
7-6-3. Slide disposable patient circuit downward into the docking station until it stops.
7-6-4. Press down firmly so there is no gap between the bottom of the Disposable Water Path and the docking station floor.
7-6-5. Close door.

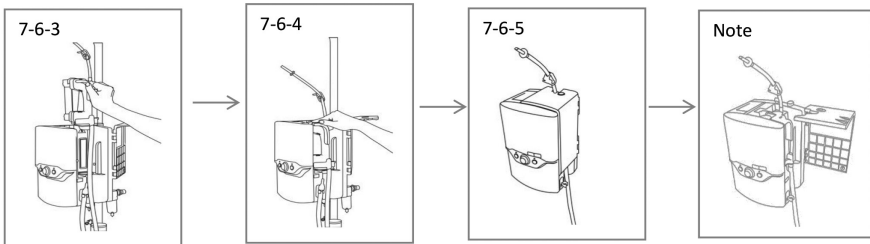
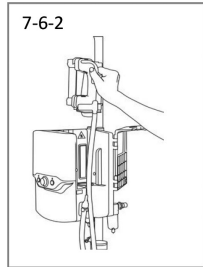

NOTE: If the door does not close easily, check that the cartridge is installed correctly and the disposable water path is fully inserted into the docking station.

CAUTION: Do not remove the disposable patient circuit while the unit is operating

Section 7 Setting up

7-6-6. General Guidelines

After connecting to the sterile water supply and unclamping the water inlet tube make sure water is flowing into the disposable patient circuit (DPC). Wait approximately 90 seconds (or 180 seconds if using a hard water bottle) before pressing the Run/Standby button. If screen is dark, press any button or turn the setting control knob prior to placing in Run mode. Uncoil and straighten the delivery tube to allow water to more easily flow into the DPC. If air pockets are observed, gently tap the delivery tube to remove the air. Insufficient water flow may lead to a temperature out of range alarm. Holding the distal end of the delivery tube below the Precision Flow® Heliox unit may further assist with water flow into the DPC.

After pressing the Run/Standby button, confirm that water is properly circulating through the machine by making sure the patient delivery tube is warm across the entire length. If good circulation cannot be confirmed, check that the water flow is not obstructed by air bubbles in the water inlet tube connected to the water supply, or in the patient delivery tube. Gently tap and wiggle the tubing, or lift it up and down in order to remove any air seen in the lines.

Reference Section 12 of the Precision Flow® Heliox Instructions for Use for information regarding alarms. Additional alarm information:

If a medium priority Water Out Alarm occurs, this may be due to the sterile water supply being empty, an obstructed inlet tube, or accumulation of air within the DPC. If the sterile water supply is empty, replace sterile water supply. If the inlet tube is obstructed, straighten the inlet tube. If necessary, remove and reseal the DPC to ensure that the DPC is fully seated in the Precision Flow® Heliox unit. Press Run/Standby button to restart the unit. If alarm persists, disconnect patient from therapy.

The DPC may be used up to 30 days. Circuit life may be less than 30 days, especially when running at higher flow rates and temperatures which may reduce the useful life of the Vapor Transfer Cartridge. This typically results in the sterile water bag filling up with air and/or a cartridge fault alarm occurring due to gas bubbles in the water path.

After addressing any alarm condition, especially those involving an obstruction of the gas or water flow, check all connections for leaks and make sure the Vapor Transfer Cartridge (VTC) is fully seated into the DPC.

Section 7 Setting up

WARNING: Use high-flow cartridge for flows 5-40 L/min and low-flow cartridge for flows 1-8 L/min.

7-7. Plug in power cord, and check that all the display indicators light up. The Precision Flow® Heliox performs a self-test:

- all icons and numeric displays light up for a few seconds
- internal sensors and control systems are checked
- if no faults are detected the unit enters STANDBY mode
- “Water Out” icon indicates there is no water in the disposable water path
- status LED is amber (solid)

7-8. The Precision Flow® Heliox unit has three controls.

Run/Standby Button – Places the unit into run or standby mode.

Setting Control Knob - Allows you to adjust the parameters.

Alarm Mute Button – Will intermittently silence alarms and also dims the display.

The Precision Flow® Heliox has three modes. Those are **Sleep**, **Standby**, and **Run**. In Sleep mode, the unit will have a blank screen and a flashing amber light showing.

The unit cannot be started from sleep. (Note: If the unit is in Standby mode and there is no user interaction with the unit for 5 minutes, the unit automatically enters Sleep mode).

To put the unit in **Standby** (from Sleep mode), simply rotate the blue Control Setting Knob to illuminate the display. You will see the three parameters of Flow, percent oxygen, and Temperature. There will also be a corresponding vapor transfer cartridge indicator on the lower right hand side which will identify what type of disposable patient circuit is in place (Blue/High or Red/Low).

To enter **Run Mode** (from Standby mode), with the screen illuminated, **simply press and release the Run/Standby Button.**

The machine will give a series of 10 beeps, and begin to power up. At this point the small light above the Run/Standby Button will change from Amber to flashing Green. During this start up, you will also see two amber alarm indicators illuminated. This is normal and is part of the Precision Flow® Heliox start up self-test.

7-9. Push or rotate the control setting knob in either direction to light up the display in STANDBY mode.

7-10. Press the Mute button to change between bright and dim display (this function is only available if no alarms are active).

7-11. To connect the sterile water supply, remove spike cap and disinfect spike with 70-90% isopropyl alcohol or equivalent. Firmly insert spike into spike port of the sterile water supply, avoiding direct hand contact. Unclamp the water inlet tube so that water (>200 ml) flows into the disposable water path and the “Water Out” alarm icon clears. (*Wait approximately 90 seconds (or 180 seconds if using a hard water bottle) before pressing the Run/Standby button)



Run/Standby button

Section 7 Setting up

7-12. Press Run/Standby button to start gas flow, pump and heater.

Press twice if the display is initially blank (once to wake the unit up, and again to put the unit into run mode). Check that the unit beeps while it tests the disposable water path and pump (see Notes below).

7-13. If all tests are passed the unit enters RUN mode. Water circulates and fills the delivery tube. The three numeric displays for flow, temperature and oxygen % display initial factory settings or the last settings used. The Status LED flashes then shows continuously green when the unit reaches desired temperature.

NOTES on startup:

- When the Run/Standby button is pressed, the unit enters a detection mode. A prompt sounds and the disposable water path icon flashes for approximately five seconds. In this mode the unit inspects the disposable water path to confirm that: a vapor transfer cartridge is present; the disposable water path is present; and the water level is correct. Power is then applied to the water pump. After five seconds the unit checks that the water pump has started and is running at the correct speed.
- If the “water out” icon is displayed and accompanied by an alarm, place unit in standby and allow DPC to fully prime. Press Run/Standby button.
- Purging of air bubbles from the circulation cannot be seen, because the gas escapes through a membrane at the top of the DWP, not into the water container.
- **Clamp the inlet tube to stop the flow of water** into disposable patient circuit whenever the unit is in standby mode.

To adjust settings: See section 8 (Adjustments)

For alarms and troubleshooting: See section 12 (Alarms)

Section 8 Adjustments

Flow rate, oxygen %, and temperature are all adjusted using the setting control knob in the center of the front panel.

- 8-1. To enter Adjustment mode, press and release the setting control knob. One of the three parameters will flash to show that it is selected for adjustment. Press the knob repeatedly to cycle the active selection through flow rate, oxygen %, and temperature.
- 8-2. To change the selected variable, rotate the knob until the desired value is displayed. Press the knob again to enter this value and select the next variable.
- 8-3. If the knob is not rotated for five (5) seconds, the unit returns to the normal Run mode or Standby mode. To re-enter Adjustment mode, press the knob again. Rotating the knob has no effect unless one of the settings has been selected and one of the displayed values is flashing.



Setting control knob

Section 8 Adjustments

NOTES on settings:

- When gas inlet pressures are less than 40 psi (276 kPa) the full specified range of flows and oxygen mixtures is not available. The Precision Flow® Heliox detects the actual inlet pressures and calculates the range of values that can be achieved. An alarm sounds if the operator attempts to make settings outside this range.
- If oxygen is not connected, the blender setting will be fixed at 21%. If air is not connected the setting is fixed at 100%. An audio signal sounds if the operator attempts to set any other value.
- If a **HIGH-FLOW** cartridge is installed the flow cannot be set below **5 L/min**.
- If a **LOW-FLOW** cartridge is installed the flow cannot be set above **8 L/min**.

NOTES on adjustment:

- Transient temperature changes may occur after rapid changes in flow settings.
- During warmup the temperature display shows the actual temperature of the gases being delivered, not the set value.
- In Run mode the display shows the current set values for flow rate, oxygen %, and temperature.
- The setting control knob is sensitive to speed. Rotate quickly for large increments and slowly for small increments.
- If the unit is completely powered down (disconnection of AC power), then the unit will return to default settings

Section 9 Connecting to patient

- 9-1. Wait for the unit to reach 33°C **before** placing the cannula (applied part) on the end of the patient delivery tube. The flashing green Status LED becomes steady when the set temperature is reached.
- 9-2. Check water level, temperature display, gas flow rate, and oxygen percentage.
- 9-3. Size cannula (applied part) to patient by ensuring that nasal prongs do not fit tightly into nares (1/2 the diameter of the nares).
- 9-4. Attach correct sized cannula (applied part) for the patient and vapor transfer cartridge onto the delivery tube. Adjust the flow to the desired rate and fit the cannula to the patient. See appendix table for cannula flow rates. DPC flow ranges are shown in the table below:

Cartridge	Cannula type	Operational flow rates
High Flow	Adult, pediatric & small adult, pediatric small*	5-40 L/min
Low Flow Patients weighing less than 3 Kg must always be put on Low Flow	Premature, solo, neonatal, infant, intermediate infant, pediatric small*	1-8 L/min

*Pediatric small cannula is intended to deliver flows from 1-20 L/min

Section 9 Connecting to patient

WARNINGS:

- Always follow aseptic technique (including proper hand washing and avoiding direct hand contact with connection points) when setting up the Precision Flow® Heliox and Standard Precautions when placing on a patient.
- Cannula prongs should not obstruct more than 50% of the nares of the patient.
- Change nasal cannulas when soiled. Replace cannulas according to clinical judgment and hospital policy but not to exceed 30 days continuous use.
- To reduce the risk that the patient may aspirate condensed water from the breathing circuit, regularly observe the patient and output of the patient interface for excess water, and if detected remove patient interface from the patient. Water in the center lumen can result from condensation or due to a leak from the outer lumens that surround the breathing circuit.

NOTES:

- The Vapotherm approved interface should be connected to the patient only when the unit has reached at least 33°C.
- Droplets of condensation may appear at the end of patient delivery tube while unit is warming up. This is normal and will stop within a few minutes when set temperature is reached and the cannula is fitted to the patient.
- Some condensation around the nose is possible. In addition, a high moisture level may mobilize mucus from nose and sinuses. Make sure patient has a supply of tissues.
- The unit should not be placed in Standby mode for extended periods of time. For pauses in therapy, keep the unit in RUN mode, remove cannula from the patient, and set the parameters to the lowest available setting. To reinitiate therapy, before the cannula is placed on patient, clear accumulated condensation.

Section 10 Operations: General Guidelines

WARNINGS:

- Never connect the unit to a patient until it reaches at least 33°C. Allow the unit to warm-up to purge condensate and prevent patient discomfort due to cold or partly humidified gas.
- Condensation in the cannula may occur in certain ambient conditions at flow rates less than 5 L/min (low flow cartridge) or less than 10 L/min (high flow cartridge). To minimize condensation it is recommended not to set the temperature higher than 34°C, if using flow rates less than 5 L/min.

- 10-1. Check that water is properly circulating through the disposable by making sure the patient delivery tube is warm across the entire length. If good circulation cannot be confirmed, check that the water flow is not obstructed by air bubbles in the patient delivery tube.
- 10-2. Check that the patient delivery tube will not be occluded by the patient's position or moving bed structures.
- 10-3. Take precautions to minimize cooling of the unheated cannula by trying to maintain contact with the patient's skin and insulating the exposed portion of the cannula with bedding.
- 10-4. During operation the door should be closed.
- 10-5. Check inlet gas traps for contaminants and press valve to empty any condensate, if present.
- 10-6. Check that nothing blocks the vent on the back of the unit.

Section 11 Changing the disposable patient circuit

The disposable patient circuit, consisting of the disposable water path, vapor transfer cartridge and delivery tube, is marked for 30 days single patient use. Change disposable patient circuit when visibly soiled or contaminated. Replace according to clinical judgment and hospital policy but not to exceed 30 days continuous use.



- 11-1. Stop the unit by pressing the Run/Standby button. Unit will enter Standby mode.
- 11-2. Clamp the water inlet tube connected to the sterile water supply.
- 11-3. Open the door to expose the disposable water path.
- 11-4. Lift the disposable patient circuit out of the Precision Flow® Heliox unit and discard in accordance with institutional guidelines.
- 11-5. Wipe down the docking station with Super Sani-Cloth®. The Precision Flow® Helio must always be cleaned and disinfected between patients.

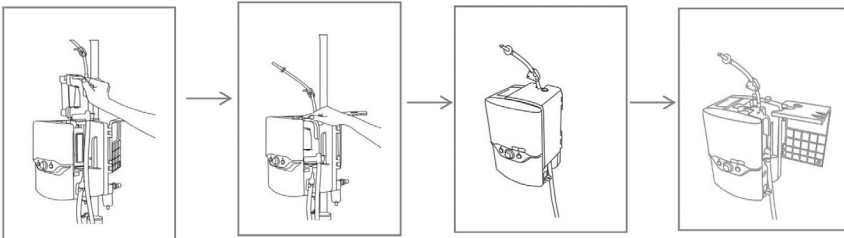

NOTE: If the door does not close easily, check that the cartridge is installed correctly and the disposable water path is fully inserted into the docking station.

WARNINGS:

- **The heater plates on the docking station and disposable water path may be hot !**
- Universal precautions and aseptic technique must be used in handling the disposable parts.



- 11-6. Open a new vapor transfer cartridge, delivery tube and disposable water path.
- 11-7. Install the vapor transfer cartridge and delivery tube in the disposable water path as described in Section 7 (Setting up).

CAUTIONS:

- The sensor windows in the docking station must not be scratched or damaged. If necessary, wipe down the docking station with 70-90% isopropyl alcohol wipes or Super Sani-Cloth®. **Never use sharp instruments or abrasive cleaners to clean windows.**

- 11-8. Slide the disposable patient circuit into the docking station and close the door.
- 11-9. Hang new sterile water supply on the hook of the Vapotherm approved roll stand.
- 11-10. Wipe the spike on the water inlet tube with 70-90% isopropyl alcohol and insert into spike port of the sterile water supply.
- 11-11. Re-start the unit.

Section 12 Alarms

The essential performance of the device consists of proper humidification at high flow rates, heating of water to physiologic levels, and delivery of appropriate FiO_2 . The User needs to appropriately respond to alarms and perform required maintenance, to ensure the essential performance of the device is maintained.

Fault conditions are indicated by icons displayed on the front panel and by audio signals.

- Unless indicated otherwise, alarms will self-clear when the fault condition is corrected.
- The MUTE button will silence low priority alarms for 2 minutes and medium priority alarms for 20 seconds (except for Blocked Tube alarm, which can only be muted for 5 seconds or less while the alarm resets). General fault alarms cannot be muted.
- Gas flow continues during many alarm conditions -except when the O_2 supply gas pressure is outside specified range.
- An amber LED above the Mute button indicates that one or more alarms are muted.

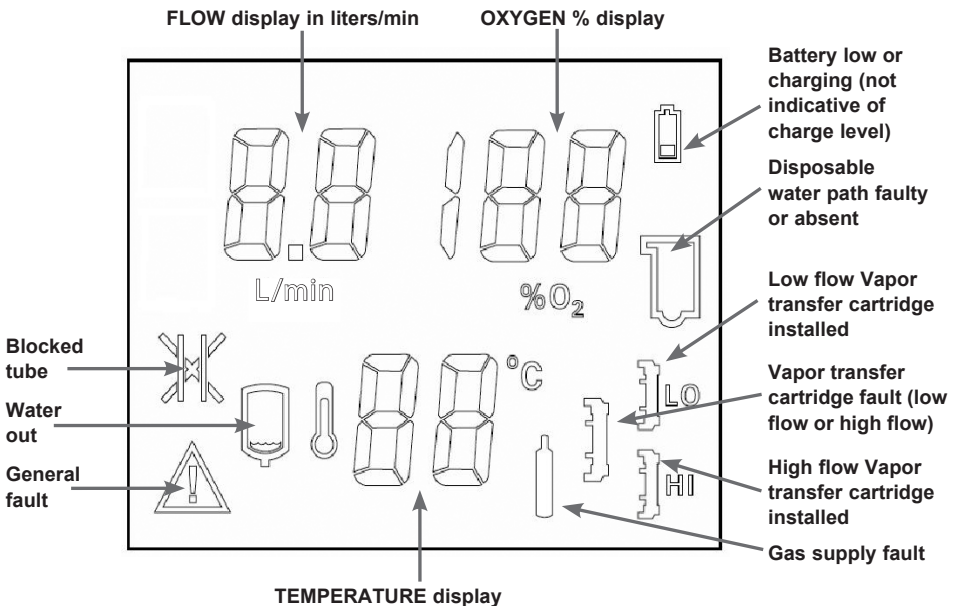

ALARM TONE PRIORITIES

- **MEDIUM PRIORITY** alarms require immediate attention and are indicated by rapid intermittent tones (fast triple beeps).
- **LOW PRIORITY** alarms require attention as soon as reasonably possible and are indicated by infrequent intermittent tones (slow double beeps).

In addition to the medium and low alarms, the Precision Flow® Heliox emits the following audio signals:







- single dull tone that sounds when the unit switches from run to standby mode
- single high pitched beep whenever you press the control setting knob
- low pitched buzz when you try to change a setting that cannot be changed or when alarm conditions prevent entering the run mode
- five slowly repeating single beep during disposable water path testing when entering run mode.

Section 12 Alarms

Technical Alarms - Alarm Table









GENERAL FAULT ALARMS: Failures in the control or measurement systems will cause a General Fault alarm indicated by this icon accompanied by the Temp display showing numbers between 50 & 84 (error codes) and dashes in the O₂ and Flow displays. When an error code is displayed, gas delivery is stopped. The user needs to monitor the treatment and respond to general fault alarms. See the alarm icon descriptions below for specific alarm conditions and associated information. General Fault alarms cannot be silenced with the mute button. To reset, first disconnect the unit from AC power and then press the Run/Standby button. With the exception of O₂ sensor replacement, the unit must be repaired by an approved service facility. Replacement of other components outside of an approved service facility could result in unacceptable risk.

Alarm icon	Audio Signal	Indicates	Cause	Action
General fault illuminated and flow parameter showing " - - " (flashing) 	Medium Priority Cannot be muted	Malfunction of sensor or control system	Internal component failure	Check gas supply. If not corrected, disconnect patient. Unplug AC power, press and hold Run/Standby button for 3 seconds to clear the alarm, send for service.
General fault illuminated and flow parameter showing " - " (flashing) 	Medium Priority Cannot be muted	Desired flow cannot be achieved	Insufficient supply pressure for desired flow rate	Increase supply pressure
General fault illuminated and O ₂ parameter showing " - " (flashing) 	Medium Priority Cannot be muted	O ₂ sensor fault	Depleted or defective O ₂ sensor	Unplug AC power, press and hold Run/Standby button for 3 seconds to clear the alarm. Replace O ₂ sensor. Restart unit.
General fault illuminated and O ₂ parameter showing " - " (flashing) 	Medium Priority Cannot be muted	Desired Oxygen % cannot be maintained	Interruption of oxygen supply, flow or pressure	Verify oxygen supply system has gas and pressure
Blocked tube (flashing) 	Medium Priority Mutes only during brief reset period	High back pressure	Obstructed or kinked cannula/delivery tube, incorrect cannula for flow rate, or DPC improperly seated	Clear obstruction, check cannula type, re-install DPC
Water out 	Medium Priority	No water in disposable water path. Gas flow continues without heating or water circulation.	Sterile water empty, or obstructed inlet tube.	Replace water bag or straighten inlet tube. Restart unit. If alarm persists, disconnect patient from therapy.

Section 12 Alarms

Other Alarms - Alarm Table

Alarm icon	Audio Signal	Indicates	Cause	Action
Disposable water path (flashing) 	Medium Priority	Disposable water path faulty or not detected. Unit will not run.	Disposable water path defective, not properly seated or not installed.	If disposable water path is present, place unit into Standby, remove and replace disposable patient circuit to reset detector. Restart Unit.
Battery charging (steady) 	None	The internal battery backup is not fully charged. The unit would not run on battery for the full rated time in the event of a power failure. No action is necessary.		
Battery (flashing) 	Medium Priority	The unit is running in BATTERY mode. Gas flow and blending continue without heat or water circulation.	AC power is disconnected	Reconnect AC power.
Cartridge fault 	Medium Priority	Cartridge and/or DPC not detected. Unit will not run	RUN mode: faulty sensor or cartridge not detected.	Disconnect patient. Remove disposable patient circuit. Check cartridge installation. Check sensor windows are clean.
	Low Priority	Gas bubbles in water circulation. Unit continues to operate.	Excessive gas diffusion through cartridge fibers.	Disconnect patient. Place unit into Standby. Replace disposable patient circuit including water path, cartridge & delivery tube.
	None	Cartridge and/or DPC not detected.	STANDBY mode: missing cartridge.	Remove disposable patient circuit. Check cartridge installation.
Cartridge type 	None	Indicates type of cartridge installed (low or high flow). Not an alarm.		
Gas supply (flashing) Gas supply (continuous and flow rate numeric display flashes)	Medium Priority	Gas supply pressure outside 4-85 psi (28-586 kPa) range. Unit will not operate.	Gas supply is disconnected or exhausted.	Check gas supply and correct as necessary.
	Medium Priority	Selected flow cannot be provided from current gas supply.	Inlet gas pressure too low for selected flow rate.	Increase gas pressure or decrease flow setting.

Section 12 Alarms

Other Alarms - Alarm Table

Alarm icon	Audio Signal	Indicates	Cause	Action
General fault illuminated and temperature parameter showing " - - " (flashing) 	Medium Priority Cannot be muted	Temperature out of range.	Overheating or temperature sensor malfunction.	Cannot be corrected by user: disconnect patient. Unplug AC power, press and hold Run/Standby button for 3 seconds to clear the alarm, send for service.
Temperature numeric display flashes	Medium Priority	Temperature 2° > set point	User enters set point much lower than previous temperature.	Silence alarm and wait for temperature to drop.
		Temperature 2° < set point	Very low water temperature after bag replacement.	Silence alarm and wait for temperature to rise.

Section 13 Shut down

- 13-1. Stop the unit by pressing the Run/Standby button. Unit will enter Standby mode.
- 13-2. Clamp the water inlet tube.
- 13-3. Open the hinged door, remove the disposable water path with vapor transfer cartridge and delivery tube attached by sliding it upwards out of the docking station.
- 13-4. Discard all disposables according to hospital guidelines.
- 13-5. Disconnect unit from AC power.

Note: The Precision Flow® Heliox has **no ON/OFF switch**. Plug the unit into a wall outlet to keep the battery fully charged.

CAUTION: Even a fully charged battery will lose its charge over a period of weeks when the unit is not connected to an AC source. It is recommended that the unit is connected to AC for at least two hours once a month to maintain battery charge.

Section 14 Routine maintenance

14.a The internal backup battery should be replaced every two years. Contact Vapotherm for further information.

14.b Oxygen sensor

The oxygen sensor (part no. 3003011) should be replaced annually. It is accessible by removing a panel at the back of the unit, and can be changed in a few minutes by the user or biomedical engineer. Use only Vapotherm approved parts.

To replace oxygen sensor:

1. Loosen three (3) captive screws from the access panel. Pull the panel away from the unit.
2. Disconnect the cable connector: grasp with pliers and pull straight back.
3. Unscrew the sensor body from its housing. Insert new sensor and screw in.
4. Plug in cable and replace cover. When replacing cover, be certain not to pinch cables. Do not over-tighten screws.
5. Apply label to indicate when replacement is due or write the date with a permanent marker.

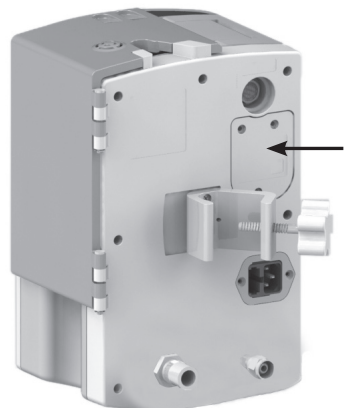

Oxygen sensor access panel

CAUTION: Sensor should be hand-tight only. Do not use tools.

Section 14 Routine maintenance

14.c Fuses

The mains fuses (two GMA - 3A F250 V, 5 x 20mm) are located next to the power cord inlet. Ensure that the unit is unplugged before replacing fuses. Use a small flat blade screwdriver to pry open the fuse compartment door to access fuses.

NOTE: Vapotherm Preventative Maintenance Kits include all parts required for annual (PM Kit P/N 3100904) and biennial (PM Kit P/N 3100906) routine maintenance.

Section 15 Cleaning and disinfection

The entire disposable patient circuit is disposable and no disinfection is required. The main unit, including the docking station for the disposable water path should be wiped down with Super Sani-Cloth®. Unplug the Precision Flow® Heliox while cleaning and disinfecting. The Precision Flow® Heliox must always be cleaned and disinfected between patients. Follow the steps below to ensure a clean and disinfected device.

- Wipe down the main unit with Super Sani-Cloth®.
- Examine for visible soil. If visible soil is present, use a brush (e.g. Spectrum M16 brush) to remove visible soil.
- Wet the main unit with another Super Sani-Cloth®. Keep the surface wet for at least six minutes. Use additional Super Sani-Cloth® if needed.

The Precision Flow® Heliox must be cleaned and disinfected with Super Sani-Cloth®. In addition, if hospital procedures require, the following may be used: 70-90% isopropyl alcohol, 2% (maximum) Chlorine cleaning solution (Sodium Hypochlorite), 6% (maximum) Hydrogen Peroxide cleaning solution, Caviwipes TM, AF3 Germicidal, Incidin® OxyWipe, Bacillo® 30 Tissues, Clinell® Alcohol Wipes, or Tuffie Disinfectant Wipes-Cloth®.

NOTE: The transparent sensor ports in the docking station must be clean. Refer to Section 4 for a drawing of the docking station with arrows pointing to the location of the sensor ports. Visually examine the sensor ports for a transparent finish to confirm cleaning has been effective. The unit will not operate if the sensors do not receive a clear signal.

CAUTION: Do not use organic solvents or abrasive cleaners. Hypochlorite solutions liberate toxic gases such as chlorine when acidified or heated. The reaction with ammonia or with substances that can generate ammonia can produce chloramines which are also toxic and have explosive potential. Do not expose the surface of the heater plate on the Precision Flow® Heliox unit to concentrations of Chlorine solution (Sodium Hypochlorite) for a prolonged period of time, as this may cause surface damage to the metal plating.



If not cleaned properly with approved cleaners, the Precision Flow® Heliox unit will fail to operate correctly.

Section 16 Specifications

PHYSICAL CHARACTERISTICS

Dimensions:

Height 11.5"(300mm), width 8"(200mm), depth 7"(180mm), excluding Vapotherm approved roll stand clamp.

Weight:

10.6 lb (4.81 kg) without disposable patient circuit
 Circulating Water Volume: 400 ml approx. including delivery tube and vapor transfer cartridge.

Mounting:

Rear mounted clamp fits Vapotherm approved roll stands up to 1.5"(38mm) diameter.

Gas Connections:

Standard non-interchangeable fittings for medical air and oxygen.

FUSES: (Qty 2) GMA 3A F250 V 5mm x 20mm 

SYSTEM REQUIREMENTS

Power:

100-240 VAC, 50-60Hz, < 350VA during warm up, approx. 80VA in steady state (depends on flow rate and temperature).

Back-up power:

4.8V nickel-metal hydride battery pack.

Gas supply:

Heliox and oxygen at inlet pressures between 4 and 85 psi (28-586 KPa). Heliox supply mixture 79% Helium 21% Oxygen (80/20).

NOTE: The full range of flows and oxygen percentage is available only if both gases are present at inlet pressures of at least 40 psi (276 kPa). Unit is calibrated at Vapotherm using 100% O₂

Water:

Sterile water for inhalation in pre-filled sealed container.

Recommended water change interval based on flow rate and operation at 37°C.

Flow Rate	Average water usage per day	Recommended Change Interval
1-10 L/min	650 ml	500 ml / 12 h
10-20 L/min	1300 ml	500 ml / 8 h
20-30 L/min	2000 ml	1000 ml / 12 h
30-40 L/min	2600 ml	1000 ml / 8h

Section 16 Specifications

PERFORMANCE

Temperature:

Range- 33 to 39°C at exit from the delivery tube, adjustable

Resolution- 1°C

Accuracy- $\pm 2^\circ\text{C}$

Warm up time:

$\pm 2^\circ\text{C}$ of 33°C set point < 5 minutes (at ambient 23°C)

NOTE: Time required to heat is dependent on the temperature set point, flow rate and ambient temperature. Due to normal system variation, it is possible not all combinations of temperature and flow rate may be achieved, in particular when set to the higher settings.

Humidification:

Minimum of 12 mg/L

Oxygen percentage:

Range- 21 to 100% O₂

Accuracy- $\pm 2\%$

Resolution- 1%

NOTE: At flow rates less than 3 L/min, for 22% & 23% oxygen blend, the delivered oxygen is 21%. At flow rates less than 3 L/min, for 98% and 99% oxygen blend, the delivered oxygen is 100%.

Section 16 Specifications

PERFORMANCE

Flow rate resolution:

Vapor transfer cartridge	Range	Resolution
Low flow	1 - 8 L/min	0.5 L/min
High flow	5 - 40 L/min	1.0 L/min

Accuracy- $\pm 10\%$ or 0.5 L/min whichever is greater

STANDARDS

Designed to conform to the following standards:

IEC 60601-1

IEC 60601-1-2:2014

UL60601-01

CSA C.22.2/No. 60601.1

AS/NZS 3200.1.2

EN60601-1

ISO/IEC 80601-2-74

ISO 11195

ISTA-2A

ENVIRONMENTAL

Operating

Ambient temperature: 18-30°C

Ambient relative humidity: 20-90% RH non-condensing

Ambient Pressure: 86 kPa to 108 kPa – Not to be used in hyperbaric conditions

Altitude up to 1,948 m (6,392 ft)

Storage and Shipping

Ambient temperature: -10 - +50°C

Ambient relative humidity: 20-90% RH

ALARM SOUND PRESSURE RANGES

Medium Priority Alarm

47 dB measured 1m from unit

Low Priority Alarm

45 dB measured 1m from unit

EXPECTED LIFE

The Precision Flow® Heliox has an expected life of 5 years with typical use of roughly 150 days per year. Actual life will vary depending on whether typical use is greater than 150 days per year, quality of gas supplies, cleaning with proper agents, operating per Instructions for Use instructions and cautions, and the timely execution of routine maintenance. More frequent use, dirty and or wet gas supplies, or the use of organic or abrasive cleaners will reduce the expected life.

Appendix

Standard Cannula

Size	Part No.	Prong Outer Dia. (mm)	Max. Flow
Premature	MN1100A	1.5	8
Neonatal	MN1100B	1.5	8
Infant	MI1300	1.9	8
Intermediate Infant	MI1300B	1.9	8
SOLO cannula	SOLO1300	1.9	8
Pediatric Small	MPS1500	1.9	20
Pediatric/Adult Small	MP1500	2.7	40
Adult (base)	MA1700	4.8	40

Audio Tone Characteristics

Tone Type	Fo (Hz)	Pulses per Burst	Pulse Spacing (ms)	Pulse Duration (ms)	Inter-Burst Interval (s)
Medium Priority	660	3	200	200	2.5
Low Priority	660	2	200	200	22
Run/Standby Transition	440	1	-	30	-
Encoder Know Press	880	1	-	30	-
User Interface Error	220	1	-	100	-
Self Test	660	5	1000	50	-
DWP Detecting	660	1	-	100	0.9

Appendix

Precision Flow Software Operating Modes Diagram

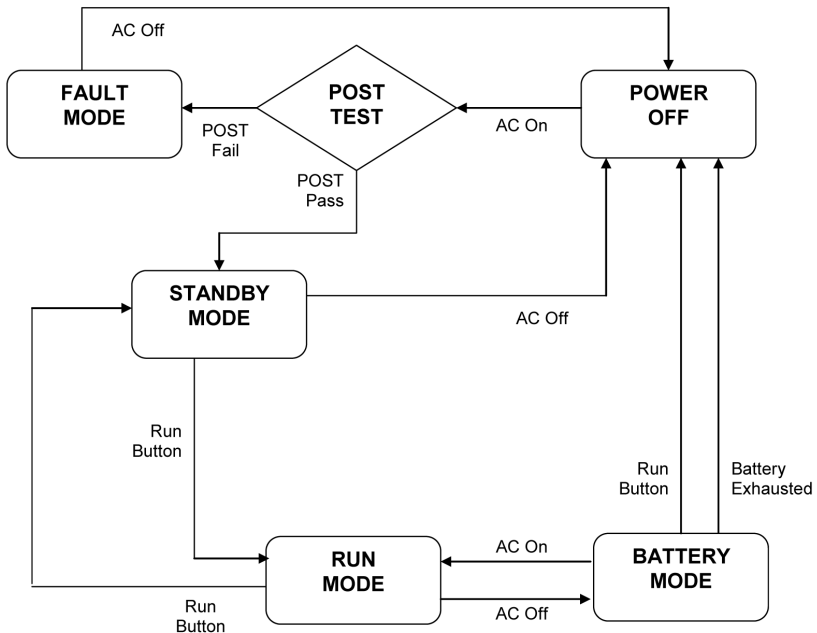

The diagram illustrates the operating modes for the unit.

- Immediately on connection to AC power a POST (Power-On Self-Test) is run to verify proper function of subsystems, sensors and actuators in the Precision Flow® Heliox.
- On successfully completing the POST the unit enters STANDBY unless there is a test failure, when the system alarms, enters FAULT mode and cannot be started.
- The Precision Flow® Heliox enters RUN mode from STANDBY when the RUN/STANDBY button is pressed. Normal operation starts. The pump, heater and gas flow proportioning systems start. Sensors and alarms are active and flow, temperature and oxygen % can be set.
- To return to STANDBY, the RUN/STANDBY button is pressed again.
- If AC power is disconnected when the unit is in RUN mode it enters BATTERY mode. If the battery is fully charged, gas mixing and metering continues for at least 15 minutes, but water is not circulated or heated. When the battery is discharged the unit enters the POWER OFF mode.
- If AC power is disconnected in STANDBY, the unit enters POWER OFF mode.

Appendix

Electromagnetic Compatibility (EMC)

The Precision Flow® Heliox is suitable for the electromagnetic environment of typical commercial or hospital settings.

During the immunity testing described below, the Precision Flow® Heliox continued to deliver proper humidification at high flow rates, heating of water to physiologic levels, and delivery of appropriate FiO₂.

WARNINGS:

- Portable RF communications equipment (including peripherals such as antenna cables and external antennas) should be used no closer than 30 cm (12 inches) to any part of the Precision Flow® Heliox System, including cables specified by Vapotherm. Otherwise, degradation of the performance of this equipment could result.
- Use of this equipment adjacent to or stacked with other equipment should be avoided because it could result in improper operation. If such use is necessary, this equipment and the other equipment should be observed to verify that they are operating normally.
- Use of accessories, transducers and cables other than those specified or provided by the manufacturer of this equipment could result in increased electromagnetic emissions or decreased electromagnetic immunity of this equipment and result in improper operation.

Guidance and manufacturer's declaration - electromagnetic emissions		
The Precision Flow® Heliox is intended for use in the electromagnetic environment specified below. The customer or the user of the Precision Flow® Plus should assure that it is used in such an environment.		
Emissions test	Compliance	Electromagnetic environment- guidance
RF emissions CISPR 11	Group 1	The Precision Flow® Heliox uses RF energy only for its internal function. Therefore, its RF emissions are very low and are not likely to cause any interference in nearby equipment.
RF emissions CISPR 11	Class A	The Precision Flow® Heliox is suitable for use in all establishments other than domestic.
Harmonic emissions IEC 61000-3-2	N/A	Warning: This equipment/system is intended for use by healthcare professionals only. This equipment/system may cause radio interference or may disrupt the operation of nearby equipment. It may be necessary to take mitigating measures, such as re-orienting or relocating the Precision Flow® Heliox or shielding the location.
Voltage fluctuations/ flicker emissions IEC 61000-3-3	N/A	

Electromagnetic Immunity		
The Precision Flow® Heliox is intended for use in the electromagnetic environment specified below. The customer or the user of the Precision Flow® Heliox should assure that it is used in such an environment.		
Immunity Test	Compliance Level	Electromagnetic Environment - Guidance
Electrostatic discharge (ESD) IEC 61000-4-2	±8kV air ±15kV contact	Floors should be wood, concrete or ceramic tile. If floors are covered with synthetic material, the relative humidity should be at least 30%.
Electrical fast transient / burst IEC 61000-4-4	±2kV for power supply lines +/- 1 kV I/O cables	Mains power quality should be that of a typical commercial or hospital environment.
Surge IEC 61000-4-5	± 1 kV differential mode +/- 2kV line to ground	Mains power quality should be that of a typical commercial or hospital environment.
Voltage dips, short interruptions and voltage variations on power supply input lines IEC 61000-4-11	>95% U _r Dip for .5 Periods at <5% U _r Test Level. 60% U _r Dip for 5 Periods at 40% U _r Test Level. 30% U _r Dip for 25 Periods at a 70% U _r Test Level.	Mains power quality should be that of a typical commercial or hospital environment. If the user of the Precision Flow® Heliox requires continued operation during power mains interruptions beyond that provided by the battery, it is recommended that the Precision Flow® Heliox is powered from an uninterruptible power supply.
Power frequency (50/60 Hz) magnetic field IEC 61000-4-8	4 A/m	Power frequency magnetic fields should be at levels characteristic of a typical location in a typical commercial or hospital environment.
NOTE: U _r is the A/C. mains voltage prior to application of the test level.		

Electromagnetic Immunity		
The Precision Flow® Heliox is intended for use in the electromagnetic environment specified below. The customer or the user of the Precision Flow® Heliox should assure that it is used in such an environment.		
Immunity Test	Compliance Level	Electromagnetic Environment - Guidance
Conducted RF IEC 61000-4-6	3 Vrms 6 Vrms in ISM and amateur radio bands	The Precision Flow® Heliox is suitable for the electromagnetic environment of typical commercial or hospital settings.
Radiated RF IEC 61000-4-3	3 V/m	

Appendix

Recommended separation distances between portable and mobile RF communications equipment and the Precision Flow® Heliox			
Max Output Power (Watts)	Separation (m) 150kHz to 80MHz $D=(3.5/\sqrt{P})$	Separation (m) 80 to 800MHz $D=(3.5/\sqrt{E1})$	Separation (m) 800MHz to 2.5GHz $D=(7/\sqrt{E1})$
0.01	.12	.12	.23
0.1	.37	.37	.74
1	1.17	1.17	2.33
10	3.69	3.69	7.38
100	11.67	11.67	23.33

Warranty

Vapotherm expressly warrants, for a period of one (1) year from the date of shipment by Vapotherm to the initial purchaser of the Precision Flow® Heliox device ("Customer") that the Precision Flow® Heliox device shall meet the specifications set forth in the applicable official operating instructions for use provided with each Precision Flow® Heliox device (the "Instructions"). The sole remedy for this warranty is that Vapotherm shall, at its sole option, either refund, repair or replace any or all of any Precision Flow® Heliox device that is defective at no cost to the Customer. Vapotherm shall pay any shipping charges required in repairing or replacing any part or all of a Precision Flow® Heliox device during the warranty period. Thereafter, shipping charges shall be paid by the Customer. Customer shall also be responsible for the cost of labor for repairs. This warranty does not apply to any disposable component to the Precision Flow® Heliox device, including without limitation the disposable patient circuits and hoses supplied with the Precision Flow® Heliox device.

The warranty set forth herein shall become null and void if: (1) the Precision Flow® Heliox device is not used or serviced in accordance with the applicable Instructions or any related preventative maintenance instructions provided with the Precision Flow® Heliox device; or (2) the Precision Flow® Heliox device is opened or tampered with, or if repairs or service are performed or attempted on the Precision Flow® Heliox device by anyone other than Vapotherm or a Vapotherm-certified service center.

EXCEPT AS EXPRESSLY SET FORTH ABOVE, VAPOTHERM MAKES NO WARRANTY, EXPRESS, IMPLIED, STATUTORY OR OTHERWISE, WITH RESPECT TO THE PRODUCTS OR ANY OTHER ITEMS PROVIDED BY VAPOTHERM, AND HEREBY EXPRESSLY DISCLAIMS ANY OTHER FORM OF WARRANTY, INCLUDING, WITHOUT LIMITATION, ANY WARRANTY OF MERCHANTABILITY OR FITNESS FOR A PARTICULAR PURPOSE. THIS STATED WARRANTY IS EXCLUSIVE AND IN LIEU OF ALL OTHER WARRANTIES PROVIDED BY LAW.

For further information contact:



Vapotherm Inc.
100 Domain Drive
Exeter, NH 03833
USA
Phone: 603-658-0011
Fax: 603-658-0181
www.vapotherm.com

May be patented
www.vapotherm.com/patents

Technical Support Line
Domestic: 855-557-8276
International: 603-658-5121
TS@Vtherm.com



AJW Technology Consulting GmbH
Königsallee 106
40215 Düsseldorf
Germany
Phone: +49 (0) 211 3013 2232



VAPOTHERM®

Vapotherm Inc.
100 Domain Drive
Exeter, NH 03833
USA
Phone: 603-658-0011
Fax: 603-658-0181